



Magnetic Inductive Flowmeter

for conductive fluids



measuring
•
monitoring
•
analysing

DMH



- Measuring range: 0.4...2500 m³/h
- Accuracy: ±0.3% of reading
± 0.01% x Q_{max}
- p_{max}: PN40; t_{max}: -20...+150 °C
- Connection: flange DN 15...300,
ANSI ¾" ...12"
- Lining material: hard rubber,
soft rubber, Wagunit, PTFE
- Outputs: analogue with HART®,
pulses and status



KOBOLD companies worldwide:

ALGERIA, ARGENTINA, AUSTRALIA, AUSTRIA, BELGIUM, BULGARIA, CANADA, CHILE, CHINA, COLUMBIA, CZECHIA, DOMINICAN REPUBLIC, EGYPT, FRANCE, GERMANY, GREAT BRITAIN, HUNGARY, INDIA, INDONESIA, IRAN, ITALY, MALAYSIA, MEXICO, MOROCCO, NETHERLANDS, PERU, PHILIPPINES, POLAND, ROMANIA, SINGAPORE, SLOVAKIA, SOUTH KOREA, SPAIN, SWITZERLAND, TAIWAN, THAILAND, TUNISIA, USA, VENEZUELA, VIETNAM

KOBOLD Messring GmbH
Nordring 22-24
D-65719 Hofheim/Ts.
Head Office:
+49(0)6192 299-0
+49(0)6192 299-23398
info.de@kobold.com
www.kobold.com



Description

The KOBOLD DMH flowmeter is used to measure and monitor the volume flow rate of fluids, pulps, pastes and other electrically conductive materials, without loss of pressure.

When an electrically conductive medium passes through a directional magnetic field, a voltage is induced in accordance with Faraday's Law of Induction.

The size of this measurement voltage is proportional to the mean rate of flow and consequently also to the volume flow rate.

A flowmeter consists of a sensor that picks up the measuring signal generated from the induced voltage, and a transducer that converts this signal into a standardised output signal (4-20 mA or pulses). The measurement transducer can be affixed to the sensor or mounted separately.

Pressure, temperature, density and viscosity do not affect the volume measurement. Solid fractions and gas bubbles should be avoided.

The significant properties exhibited by DMH include:

- great choice of linings
- stainless steel, Hastelloy, tantalum or platinum electrodes
- wide variety of process connections
- can be used in rough ambient conditions

Technical data

Adjustable measuring range terminal values:	0.5...10 m/s
Minimum conductivity:	≥5 µS/cm (for fluids in general) ≥20 µS/cm (demineralised water)
Accuracy:	± 0.3% of read. ± 0.01% x Q _{max}
Repeat accuracy:	± 0.15% of read. ± 0.005% x Q _{max} (reference conditions: water, measured medium temperature of 22 °C ±4K, ambient temperature 22 °C ±2K, inlet path ≥ 10 x DN, outlet path ≥ 5 x DN, Q _{max} bei 10 m/s)
Process temperature:	0...+80 °C (hard rubber, soft rubber, Wagunit) -20...+150 °C (PTFE)
Ambient temperature:	-20...+60 °C, depending on process temperature
Rated pressure:	PN 40, ASME CI150 / 300 DN15...DN50 PN 16, ASME CI150 DN50...DN200 PN 10, ASME CI150 DN250...DN300 higher pressures on request
Sensor materials	
Linings:	hard rubber, soft rubber, PTFE, Wagunit
Electrodes:	stainless steel, Hastelloy C4, tantalum, platinum, earth ring and other materials on request
Housing:	enamelled steel
Process connection:	steel or stainless steel 1.4301 flange EN1092 und ASME B16.5, wafer version, foodstuff, screw seal DIN11581, Tri-clover, other connections on request
Nominal sizes:	DN15 to DN300 other nominal sizes on request
Protection type:	IP 67 (IP 68 on request)
Transducer UMF2	
Assembly type:	compact or separate
Housing:	enamelled die-cast aluminium rotatable in 90° steps
Outputs:	galvanically isolated
Analogue:	1 x 0(4)-20 mA load: <600 Ω (>250 Ω for HART®)

Technical Data (continued):

Pulse output: passive, using optocoupler, max. 30 V, 60 mA, 1.8 W

Status: passive, using optocoupler, max. 30 V, 60 mA, 1.8 W

Power supply: 115 V_{AC} 50/60 Hz, 10 VA
230 V_{AC} 50/60 Hz, 10 VA
24 V_{AC/DC} ±10%, 10W/VA

Electrical connection: Cable connection M 20x1.5 or ½ NPT

Ambient temperature: -20...+60 °C, depending on process temperature for compact version

Protection type: IP67

Communication: HART®

Diagnosis functions: empty pipe recognition, flushing flow monitoring

Measuring range

DN	Smallest measuring range		Greatest measuring range	
	[m³/h]	[L/min]	[m³/h]	[L/min]
15	0... 0,4	0... 7	0... 6,5	0... 108
20	0... 0,6	0... 10	0... 12	0... 200
25	0... 0,9	0... 15	0... 18	0... 300
32	0... 1,5	0... 25	0... 30	0... 500
40	0... 2,3	0... 40	0... 45	0... 750
50	0... 3,6	0... 60	0... 72	0... 1200
65	0... 6	0... 100	0... 120	0... 2000
80	0... 9	0... 150	0... 180	0... 3000
100	0... 14	0... 235	0... 280	0... 4650
150	0... 33	0... 550	0... 650	0... 10 800
200	0... 58	0... 970	0... 1150	0... 19 000
250	0... 90	0... 1500	0... 1800	0... 30 000
300	0... 126	0... 2100	0... 2500	0... 41 600

Order Details (Example: DMH-1 A15 H 1 0 A 1 0)

Type/ flange material	Process connection ¹⁾ (flange conform to EN 1092-1 form B1)	Lining	Electrode material	Earth electrode material	Versions/ cable lengths	Electronics	Power supply/ cable entry point
DMH-1 = enamelled steel	A15 = DN15, PN40 A20 = DN20, PN40 A25 = DN25, PN40 A32 = DN32, PN40 A40 = DN40, PN40	H = hard rubber	1 = stainless steel	0 = without	A = compact	1 = UMF2- electronics with control unit, without HART®	0 = 230 V _{AC} M20x1.5
DMH-2 = stainless steel 1.4301	A50 = DN50, PN40 C50 = DN50, PN16 C65 = DN65, PN16 C80 = DN80, PN16	W = soft rubber	3 = Hastelloy C4	1 = stainless steel	B = separate version/2.5 m		
DMH-5 ²⁾ = wafer version	C1H = DN100, PN16 C1F = DN150, PN16 C2H = DN200, PN16 D2F = DN250, PN10 D3H = DN300, PN10	T = PTFE V = Wagunit	5 = tantalum 7 = platinum	3 = Hastelloy C4	C = separate version/5 m		5 = 230 V _{AC} ½ NPT
				5 = tantalum 7 = platinum	D = separate version/10 m		
					E = separate version/15 m		8 = 24 V _{AC/DC} ½ NPT
					F = separate version/20 m		
					G = separate version/30 m		
					H = separate version/50 m		

1) ASME-flange class 150: code Lxx, ASME-flange class 300: code Mxx (up to 1½"/DN40), other process connections on request

2) wafer version only for nominal width DN 20...200

Dimensions

Transducer UMF2

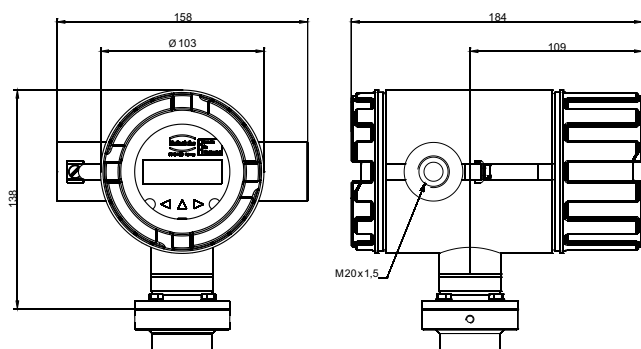

Connection box for sensor, separate version

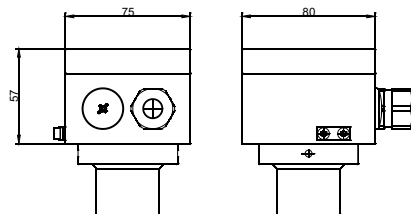

Sensor, flange connection

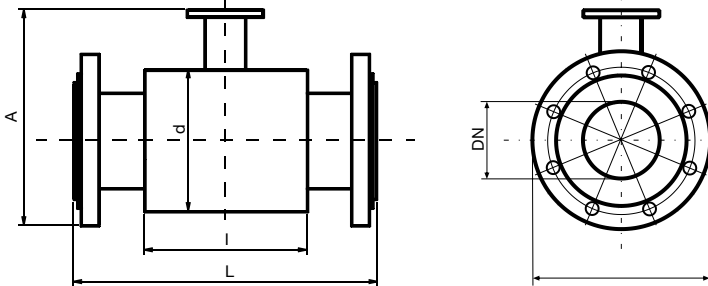

DN	PN	ASME	D [mm]	d [mm]	A [mm]	L [mm]	I [mm]	Weights* [kg]
15	40	-	95	62	164	200	66	3
20	40	3/4"	105	62	170	200	66	3
25	40	1"	115	72	180	200	96	3
32	40	1 1/4"	140	82	199	200	96	4
40	40	1 1/2"	150	92	209	200	96	4
50	16	2"	165	107	223	200	96	6
65	16	2 1/2"	185	127	244	200	96	9
80	16	3"	200	142	260	200	96	14
100	16	4"	220	162	280	250	96	16
125	16	5"	250	192	310	250	126	19
150	16	6"	285	218	340	300	126	25
200	16	8"	340	274	398	350	211	41
250	10	10"	395	370	480	450	211	54
300	10	12"	445	420	535	500	320	77

*Weights of the sensors are only approximate values, including the weight of the electronics approx. 2.4kg

Sensor, wafer flange

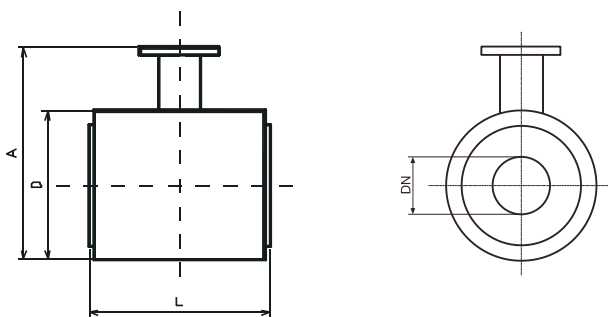

DN	PN	D [mm]	A [mm]	L [mm]	Weights* [kg]
20	40	62	145	74	1
25	40	72	158	104	2
32	40	82	168	104	2
40	40	92	179	104	2
50	16	107	192	104	3
65	16	127	212	104	3
80	16	142	227	104	4
100	16	162	247	104	4
125	16	192	277	134	6
150	16	218	303	134	8
200	16	274	359	219	10

*Weights of the sensors are only approximate values, including the weight of the electronics approx. 2.4kg